

预装式变电站 Prefabricated Substation



产品概述

本公司生产的24kV及以下预装式变电站系列产品是一种集高压开关设备、变压器、低压配电设备、低压智能开关、功率因数自动补偿、按一定接线方案组合一体的具有就地或远程操作达到遥控、遥测、通信、遥调等功能的成套配电设备。

本产品适用于额定电压为24kV及以下，额定频率为50Hz的三相交流系统的公共配电网，环网或终端供电的住宅小区，厂矿企业、大型工地、高层建筑、机场码头及临时设施等场所。

该产品能达到一、二次系统的集成化，建设过程的工厂化和施工的简单化，该组合电器集国内箱式变电站，美式箱变，欧式箱变等功能于一体。

ZYB系列变电站内部高、低压开关控制方式有手动、电动操作方式，也可以远程控制，并具有事故及报警显示和电气参数测量、通讯、电度量等功能。

产品特点

本系列产品具有占地面积小、结构紧凑、造型美观、现场安装工作量小、安装调试周期短、运行安全可靠、检修方便、根据实际需要可移动位置等功能。

外壳参照国外先进技术并根据实际情况进行设计。具有牢固、隔热通风、性能好、防尘、防小动物等特点。外壳材料有多种选择。如：钢板、铝合金板、复合板、不锈钢板、非金属材料及覆铝锌板加饰木条的材料等。

产品除可采用油浸式的全密封变压器外，还可采用干式变压器、卷铁芯变压器、非晶合金变压器等。

高压开关柜采用HXGN等国产品系列柜，亦可安装ABB或RM6等进口开关柜。

低压开关柜采用GGD或GCK等配电装置，高低压一次回路可根据用户要求进线选择布置。

Product Overview

The prefabricated substation with voltage up to 24kV is a set of high-voltage switchgear, transformers, low voltage power distribution equipment, low-voltage intelligent switch, automatic reactive power compensation, combined according to a certain combination of connection to offer local or remote operation to realize the functions of remote control, remote measuring, remote communication, remote adjustment.

This product applies to rated voltage of 24kV and below, rated frequency of 50Hz AC three-phase system of public distribution system, RMU or the residential quarters, factories and mines, large construction sites, high-rise buildings, airport terminals and temporary facilities, etc.

This product integrates primary and secondary systems to simplify the installation and commissioning. It's combined functions of pad-mounted transformer and prefabricated substation.

The Control method of ZYB series substation includes manual & electric operation type, as well as remote control type. It also has function of metering, communicating, controlling, alarm etc.

Product Characteristic

This series of products are compact, elegant, easy for installation, commissioning & maintenance, removable and reliable in operation.

The kiosk can be customized while IP grade according to IEC standard. Material of kiosk can be steel, aluminum, ABS, stainless steel, etc.

Other than oil immersed hermetical transformer, we also can adopt dry type transformer, roll core transformer and amorphous transformer.

H.V. switchgear adopts HXGN serial panel as usual while ABB & RM6 panel are also available.

L.V. switchgear adopts GGD or GCK panel. The layout of HV & LV primary circuit can be customized.

型号说明 Model Coding

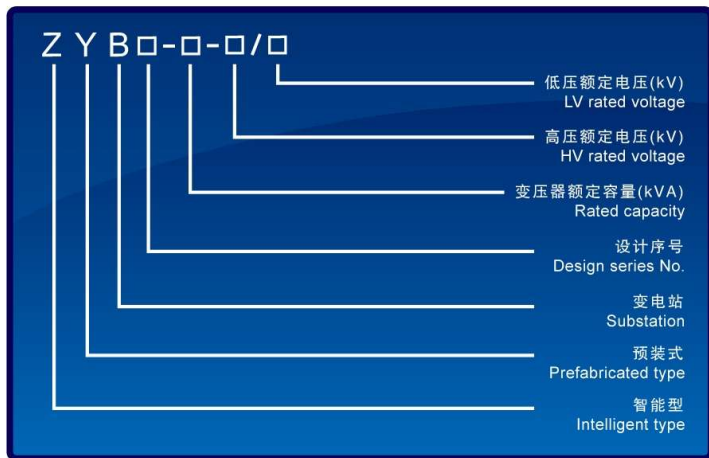

产品结构及代号 Product structure and coding



ZYB11-敞开型
Open type

高压室 H.V.chamber	变压器 Transformer
低压室 L.V.chamber	



ZYB12-通道型
Channel type

高压室 H.V.chamber	变压器室 Transformer	低压室 L.V.chamber
	通道走廊 Passage	
		低压室 L.V.chamber



ZYB13-L字型
"L" type

变压器 Transformer	高压室 H.V.chamber
低压室 L.V.chamber	



ZYB15-翻盖型
Flip type

高压室 H.V.chamber	变压器室 Transformer	低压室 L.V.chamber
--------------------	---------------------	--------------------



ZYB16-目字型
Coupled "F" type

高压室 H.V.chamber	变压器室 Transformer	低压室 L.V.chamber
--------------------	---------------------	--------------------



ZYB17-沉箱型
Caisson type

高压室 H.V.chamber	变压器室 Transformer	低压室 L.V.chamber
--------------------	---------------------	--------------------



ZYB18-品字型
"O"+reversed "E" type

变压器 Transformer	高压室 H.V.chamber
	通道走廊 Passage
	低压室 L.V.chamber

正常使用环境条件 Ambient conditions

- | | |
|---|--|
| <p>1. 变电站周围空气温度最高不超过40℃，最低不低于-25℃。</p> <p>2. 海拔高度不超过1000m。</p> <p>3. 空气湿度不大于90% (+20℃)。</p> <p>4. 户外风速不超过35m/s。</p> <p>5. 无导电尘埃，无爆炸危险，无腐蚀危险，无腐蚀金属的气体场所。</p> <p>6. 倾斜度不超过3°，无剧烈振动及无冲击的场所。</p> <p>7. 已采用高燃点绝缘油，外表用防污涂装处理，可适用于各种恶劣环境。</p> <p>8. 特殊使用条件可进行特殊设计。</p> | <p>1. Ambient air temperature $\leq 40^{\circ}\text{C}$, but $\geq -25^{\circ}\text{C}$.</p> <p>2. Altitude $\leq 1000\text{m}$.</p> <p>3. Humidity $\leq 90\%$ (+20℃).</p> <p>4. Outdoor wind speed does $\leq 35\text{m/s}$.</p> <p>5. In sites of no conductive dust, no risk of explosion, no corrosion risk, no corrosive gas to metal.</p> <p>6. Vertical tilt of $\leq 3^{\circ}$, no severe vibration and shock-free place.</p> <p>7. Applies high ignition insulation oil; outer surface is process by "three protection" and treatment by cathodic electrophoretic coating powder, which is suitable for all kinds of severe environment.</p> <p>8. Transformers for special conditions can be specially designed.</p> |
|---|--|

主要技术参数 Technical Parameters

1. 高压侧额定电压: $Un1=24\text{kV}$ 、 12kV 、 10kV 、 6.3kV (或根据用户要求)。
2. 低压侧额定电压: $Un2=690\text{V}$ 、 400V 、 230V (或根据用户要求)。
3. 变压器额定容量 (10kV为例) 与一、二次电流及高压熔断器、低压主断路器参数见表1。

1. Rated voltage on HV side: $Un1=24\text{kV}$, 12kV , 10kV , 6.3kV (Or as per client's requirement)
2. Rated voltage on LV side: $Un2=690\text{V}$, 400V , 230V (Or as per client's requirement)
3. Specification of transformer rated capacity (10kV) and primary, secondary current & HV fuse, LV main circuit breaker refers to table 1.

表1 Table 1 (主要技术参数表) (Key technical specification)

变压器额定容量 Transformer rated capacity	一次电流 (10kV) Primary current (10kV)	一次电流 (0.4kV) Secondary current (0.4kV)	高压熔断器电流 Current of HV fuse	低压主断路器电流 Current of LV main circuit breaker
Sn(kVA)	I1(A)	I2(A)	(A)	In(A)
80	4.6	115	8	125
100	5.8	144	12	160
125	7.2	180	14	250
160	9.2	231	16	250
200	11.5	289	20	400
250	14.4	361	25	400
315	18.2	455	31.5	630
400	23.1	577	40	630
500	28.9	722	50	800
630	36.4	909	63	1000
800	46.2	1160	80	1250

备注: 可根据用户要求的容量生产。 Notes: Special capacity can be fabricated as per client's requirement.

4. 高压主要技术参数见表2

Key specification of HV refers to table 2

表2 Table 2

项目 Items	单位 Unit	参数 Values
额定电压 Rated Voltage	kV	10(6.3)
额定最高电压 Rated max. voltage	kV	12(7.2)
额定频率 Rated Frequency	Hz	50
额定电流 Rated Current	A	630
额定短时耐受电流 Rated short time withstanding current	kA	20/2s 20/3s
额定峰值耐受电流 Rated withstanding current (Peak)	kA	50
额定短路开断电流 Rated short circuit breaking current	kA	50
额定工频耐受电压对地及相间/断口间 Rated power frequency withstanding voltage to earth and inter-phase/breaking points	kV	42/48(1min)
额定耐受冲击电压对地及相间/断口间 Rated impulse withstanding voltage to earth and inter-phase/breaking points	kV	75/85(1min)

5. 低压主要技术参数见表3

Key specification of LV refers to table 3

表3 Table 3

项目 Items	单位 Unit	参数 Values
额定电压 Rated voltage	V	690、400、230
主回路额定电流 Rated current for main circuit	A	100以上
额定动稳定电流 Rated dynamic stable current	kA	30、50
额定热稳定电流 Rated thermal stable current	kA	30/1s, 50/1s

6. 其它技术参数见表4

Other specification refers to table 4

表4 Table 4

项目 Items	单位 Unit	参数 Values
外壳防护等级 Protection level of enclosure		IP33 (或根据用户要求) IP33 (or as per client's requirement)
声级水平 Noise level	dB	油变 ≤ 65 (Oil immersed transformer: ≤ 65) 干变 ≤ 77 (Dry type transformer: ≤ 77)

主要回路一次方案图 Primary proposal of main circuit

1. 高压一次回路方案

高压可采用国产以及进口环网柜（施耐德、ABB、西门子等）。

HV Primary Circuit Scheme

High voltage can adopt home made or imported ring cabinet (Schneider,ABB,Siemens. etc.) .

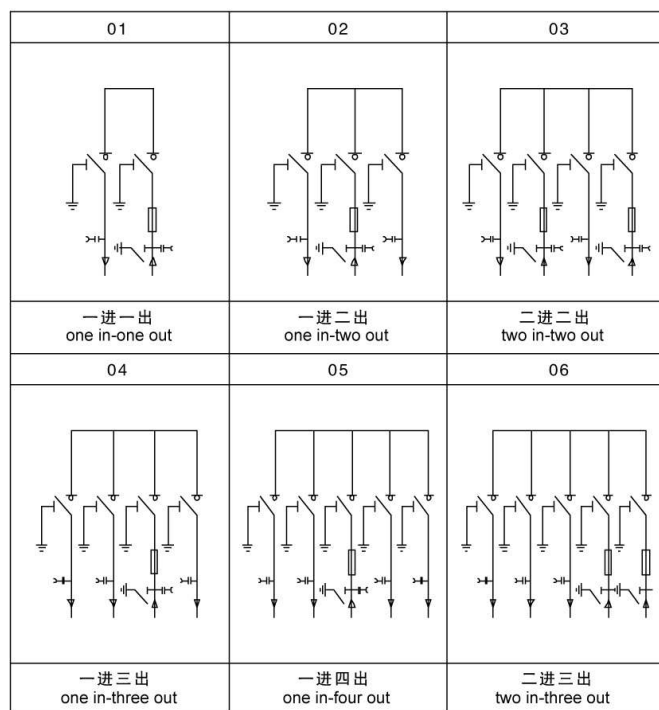

2. 低压一次回路方案（典型方案）

LV Primary Circuit Scheme (Typical proposal)

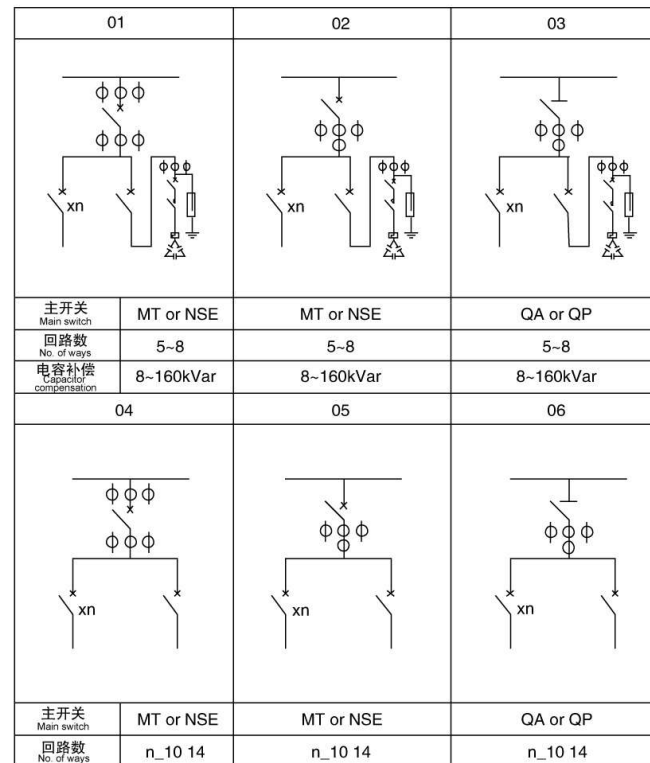

注：1. 配件根据用户需要另行选择

2. 低压配置其他方案可根据用户要求生产

Note: 1. Fittings can be selected as per customer's special requirements.

2. LV allocation scheme as per customer's special requirements.

变电站外形尺寸、安装尺寸等参数(仅作参考)

Outline dimension, installation dimension of substation (For reference only)

A. 目字型

Coupled "F" type

1. 安装尺寸图

Installation Dimensions

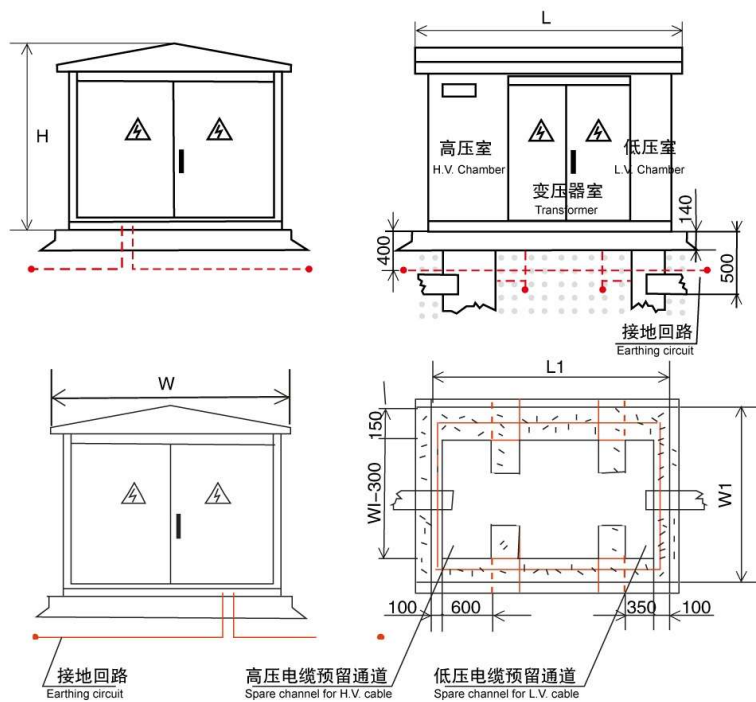

2. 外形尺寸及其他参数(以-16型为例)

Dimensions and Other Parameters

型号规格 Model	外形尺寸 (mm) Outer Dimensions	占地面积(m ²) Areas occupied	体积(m ³) Volume	重量(MT) Weight
ZYB16-400-10/0.4	L=2570;L1=2450;W=1860;W1=1700;H=1800	4.12	7.62	4.2
ZYB16-500-630-10/0.4	L=2670;L1=2550;W=2060;W1=1900;H=1950	4.85	9.70	5.0
ZYB16-800-1000-10/0.4	L=2870;L1=2750;W=2360;W1=2200;H=2200	5.71	12.28	5.3

B. 品字型

"O"+reversed "E" type

1. 外形尺寸

Outer Dimensions

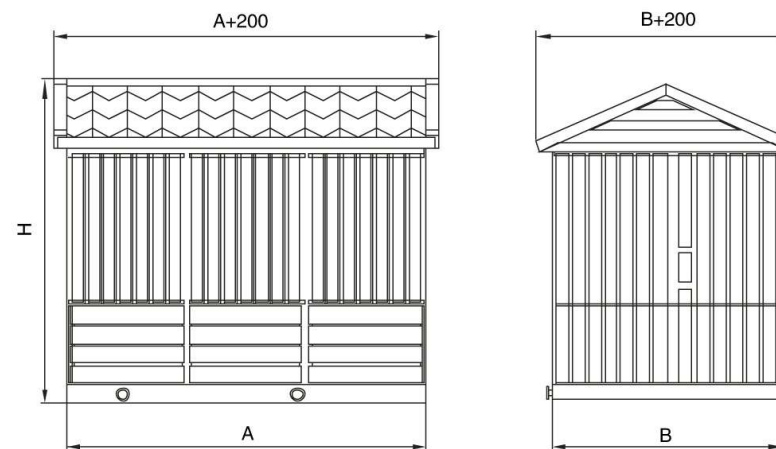

变压器容量 (kVA) Rated capacity of transformer	高压回路RM6 H.V. Circuit	A(mm)	B(mm)	H(mm)
500-630	三进一出 (包括两进一出, 一进一出)	3300	2100	2450
800	3 in-1 out (including 2 in-1 out, 1 in-1 out)	3500		
500-630	四进一出	3700	2100	2450
800	4 in-1 out			

2. 接地网安装要求:

- (1) 接地体埋设深度不小于0.6米;
- (2) 接地体双面焊接, 焊口涂防锈漆;
- (3) 接地网电阻测试必须小于4欧姆;
- (4) 整机采用三相五线制。

Requirement of earthing net installation:

- 1.The burial depth no more than 0.6 m from the toimt of connecting the land.
- 2.The connecting the land should be welded for both sides.the mouth of which should be daubed the antritrust.
- 3.The resistance of connecting the land must be smaller than 4 Ω.
- 4.Applies three-phase five-wire system.

主要回路一次方案图 Primary proposal of main circuit

3.基础图 MK1、MK2、MK3外壳地基图

MK1、MK2、MK3 Enclosure Foundation Diagram

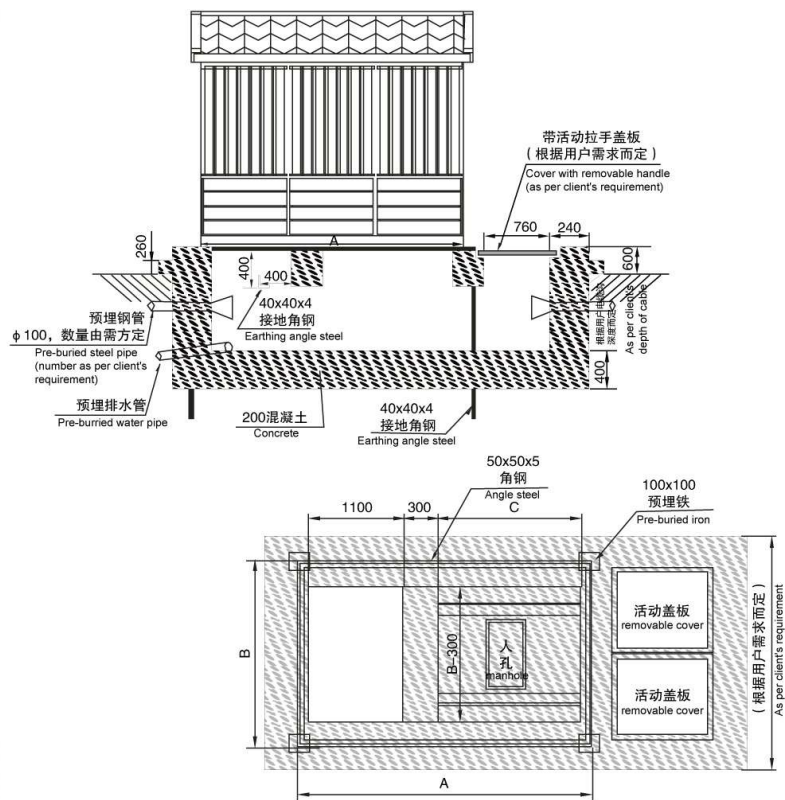

A	B	C
3300	2100	1600
3500	2100	1800
3700	2100	2000

产品应用领域及销售业绩

Product application and sales reference

该产品应用于人口密集的中心城区、街道、高速公路、桥梁、隧道、停车场、机场、港口、旅游景点、别墅、花园小区等。

The center of densely populated urban areas, streets, highways, bridges, tunnels, car parking, airports, sea ports, tourist attractions, villas, garden district, etc.

