

配电变压器 Distribution Transformer



产品概述

输电系统从遥远的发电厂将电能通过调节输送给用户，电能经高压输电线的传输，然后在几级变电站降压后，才能适合用户使用。位于最终电力用户附近的配电变压器最终将电压降到合适值。将电压降低到电气设备工作电压的变压器称为配电变压器，该类变压器作为日常照明和工厂动力用，一般低压为0.4kV及以下。配电变压器容量较小，一般在2500 kVA及以下；一次电压也较低，都在35 kV及以下。不同于普通油浸式变压器，全密封配电变压器取消了储油柜，由波纹油箱本体的翅板作为散热膨胀元件，使变压器油与大气完全隔离。我公司可根据用户需要生产一次额定电压为6, 6.3, 6.6, 10, 10.5, 11, 15, 18, 20, 24, 33, 35, 38.5kV等各种电压的配电变压器。

产品特点

- 1.采用CAD设计，性能符合IEC60076、GB1094、GB/T6451标准。
- 2.铁心采用冷轧晶粒取向硅钢片，由德国GEORG公司铁心自动生产线应用阶梯接缝工艺制造。
- 3.油箱为波纹油箱，由德国GEORG公司油箱自动生产线加工制造，表面前处理液和涂装粉末均采用国际品牌产品，油箱经自动生产流水线脱脂、酸洗、磷化、电泳处理后喷粉，再高温固化，变压器外表抗腐蚀能力强。
- 4.线圈采用高强度漆包线(或纸包线)卷绕，匝间分布均匀，绝缘结构合理，具有很强的抗短路能力。
- 5.器身采用免吊芯结构，密封件采用优质丙烯酸酯橡胶，能有效防止光老化、热老化。

Product Overview

Transmission and distribution system transmit electricity power to the end user by adjusting from far away power plants. Through high-voltage power transmission line, and then by few step-down transformer, the power is suitable for user's application. Distribution transformers located in the vicinity of the end user will eventually reduce the voltage to a suitable rating. Distribution transformers are referred to those can reduce the voltage to the electrical equipment's working voltage. Such transformers are used for daily lighting and industrial power. Generally, the low voltage is 0.4kV or below. The capacity of distribution transformer is small, generally 2500 kVA or below. And the primary voltage is 35 kV or below. Hermetically sealed transformer is different from ordinary oil-immersed transformers due to no conservator installed. The corrugated fins on the tank act as radiator, which isolate the transformer oil from atmosphere. We can fabricate distribution transformer with HV rated voltage 6, 6.3, 6.6, 10, 10.5, 11, 15, 18, 20, 24, 33, 35, 38.5kV as per client's requirement.

Product Characteristic

- 1.Distribution transformer is optimally designed by means of CAD. Its performance complies with IEC60076 and Chinese National Standards GB1094 and GB/T6451.
- 2.The core is made of high quality cold-rolled grain-oriented silicon-steel sheet. The lamination sheets are produced by automatic step-lap core lamination line from GEORG, Germany.
- 3.The oil tank is corrugated type and fabricated with automatic tank production line from GEORG, Germany. Pre-treatment liquid and coating powder on the surface made by international top brand supplier. The tank is degreasing, pickling, phosphating, electrophoresis by automatic production line, then power spray coating and heat-solidify. The surface of transformer is corrosion resistance.
- 4.The winding of Distribution transformer is made of high strength varnished wire or paper-insulated wire, which offers uniform distribution of ampere-turns, reasonable insulation structure so as to offer high ability to short-circuit withstanding capacity of winding.
- 5.The active part applies core free-hanging structure. The gasket is made of high quality acrylate rubber which can inhibit ageing caused by sun and heat.

型号说明 Model Coding

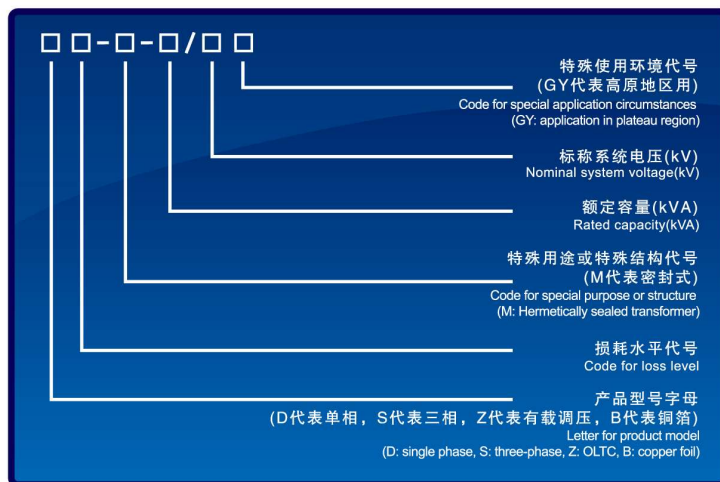

外形图 Structural Chart

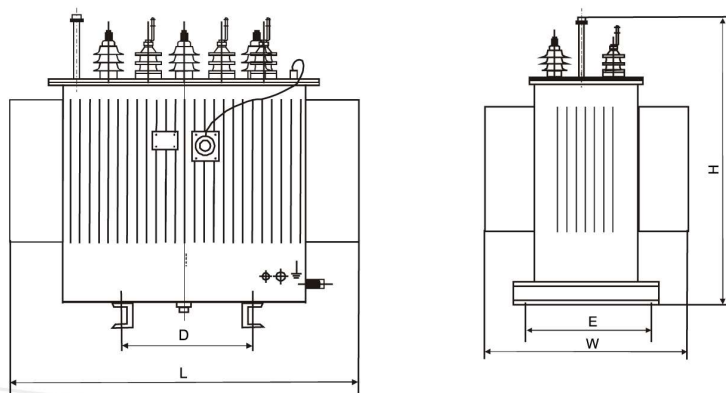

技术参数 Technical Parameters

以下数据仅供参考, 公司保留数据变动的权利
Technical data are subjected to change without prior notice

三相无励磁调压配电变压器
Three-phase distribution transformer with OCTC

型号 Model	空载损耗(kW) No load loss	负载损耗(kW) Load loss	空载电流(%) No load current	短路阻抗(%) Short-circuit impedance	重量(kg) Weight		外形尺寸(mm) Dimensions	
					油重 Oil weight	总重 Total weight	长 × 宽 × 高 L × W × H	轨距 Rail distance
S9-M-10/10	0.07	0.27	2.6	4.0	50	195	740×450×785	400×400
S9-M-20/10	0.10	0.43	2.3		60	250	740×535×810	400×400
S9-M-30/10	0.13	0.63/0.60	2.3		65	285	760×555×830	400×400
S9-M-50/10	0.17	0.91/0.87	2.0		75	345	755×595×855	400×400
S9-M-63/10	0.20	1.09/1.04	1.9		90	415	805×640×900	400×400
S9-M-80/10	0.25	1.31/1.25	1.9		85	445	785×634×900	400×550
S9-M-100/10	0.29	1.58/1.50	1.8		95	505	800×645×915	400×550
S9-M-125/10	0.34	1.89/1.80	1.7		110	580	830×740×950	550×550
S9-M-160/10	0.40	2.31/2.20	1.6		115	650	860×765×1000	550×550
S9-M-200/10	0.48	2.73/2.60	1.5		130	755	1105×720×1030	550×550
S9-M-250/10	0.56	3.20/3.05	1.4		150	910	1210×775×1105	550×550
S9-M-315/10	0.67	3.83/3.65	1.4		185	1035	1255×795×1125	550×550
S9-M-400/10	0.80	4.52/4.30	1.3		210	1125	1405×930×1195	550×550
S9-M-500/10	0.96	5.41/5.15	1.2		255	1420	1465×960×1200	660×660
S9-M-630/10	1.20	6.20	1.1		285	1670	1500×930×1370	660×660
S9-M-800/10	1.40	7.50	1.0		340	2065	1630×1075×1350	660×660
S9-M-1000/10	1.70	10.3	1.0	365	2265	1710×1155×1465	820×820	
S9-M-1250/10	1.95	12.0	0.9	515	3055	1805×1055×1615	820×820	
S9-M-1600/10	2.40	14.50	0.8	555	3375	1840×1230×1685	820×820	
S9-M-2000/10	2.68	18.90	0.5	715	4300	1925×1255×1885	820×820	
S9-M-2500/10	3.20	22.50	0.4	990	5370	2125×2370×2410	1070×1070	
S10-M-10/10	0.06	0.27	2.6	4.0	50	195	740×450×785	400×400
S10-M-20/10	0.085	0.43	2.3		60	250	740×535×810	400×400
S10-M-30/10	0.11	0.63/0.60	2.3		65	285	760×555×830	400×400
S10-M-50/10	0.15	0.91/0.87	2.0		75	345	755×595×855	400×400
S10-M-63/10	0.18	1.09/1.04	1.9		90	415	805×640×900	400×400
S10-M-80/10	0.20	1.31/1.25	1.9		85	445	785×634×900	400×550
S10-M-100/10	0.23	1.58/1.50	1.8		95	505	800×645×915	400×550
S10-M-125/10	0.27	1.89/1.80	1.7		110	580	830×740×950	550×550
S10-M-160/10	0.31	2.31/2.20	1.6		115	650	860×765×1000	550×550
S10-M-200/10	0.38	2.73/2.60	1.5		130	755	1105×720×1030	550×550
S10-M-250/10	0.46	3.20/3.05	1.4		150	910	1210×775×1105	550×550
S10-M-315/10	0.54	3.83/3.65	1.4		185	1035	1255×795×1125	550×550
S10-M-400/10	0.65	4.52/4.30	1.3		210	1125	1405×930×1195	550×550
S10-M-500/10	0.78	5.41/5.15	1.2		255	1420	1465×960×1200	660×660

型号 Model	空载损耗(kW) No load loss	负载损耗(kW) Load loss	空载电流(%) No load current	短路阻抗(%) Short-circuit impedance	重量(kg) Weight		外形尺寸(mm) Dimensions		
					油重 Oil weight	总重 Total weight	长 × 宽 × 高 L × W × H	轨距 Rail distance	
S10-M-630/10	0.92	6.20	1.1	4.5	285	1670	1500×930×1370	660×660	
S10-M-800/10	1.12	7.50	1.0		340	2065	1630×1075×1350	660×660	
S10-M-1000/10	1.32	10.30	1.0		365	2265	1710×1155×1465	820×820	
S10-M-1250/10	1.56	12.00	0.9		515	3055	1805×1055×1615	820×820	
S10-M-1600/10	1.88	14.50	0.8		555	3375	1840×1230×1685	820×820	
S10-M-2000/10	2.35	18.90	0.5		715	4300	1925×1255×1885	820×820	
S10-M-2500/10	2.80	22.50	0.4	990	5370	2125×2370×2410	1070×1070		
S11-M-30/10	0.10	0.63/0.60	2.3	4.0	70	330	760×555×930	400×400	
S11-M-50/10	0.13	0.91/0.87	2.0		70	365	755×565×880	400×400	
S11-M-63/10	0.15	1.09/1.04	1.9		90	435	805×640×930	400×400	
S11-M-80/10	0.18	1.31/1.25	1.9		85	470	785×635×930	400×550	
S11-M-100/10	0.20	1.58/1.50	1.8		90	560	800×645×955	400×550	
S11-M-125/10	0.24	1.89/1.80	1.7		105	605	855×745×980	550×550	
S11-M-160/10	0.27	2.31/2.20	1.6		115	695	860×765×1025	550×550	
S11-M-200/10	0.33	2.73/2.60	1.5		130	800	1105×720×1070	550×550	
S11-M-250/10	0.40	3.20/3.05	1.4		160	945	1235×800×1150	550×550	
S11-M-315/10	0.48	3.83/3.65	1.4		200	1090	1330×895×1170	550×550	
S11-M-400/10	0.57	4.52/4.30	1.3		225	1300	1380×875×1240	550×550	
S11-M-500/10	0.68	5.41/5.15	1.2		255	1545	1415×890×1320	660×660	
S11-M-630/10	0.81	6.20	1.1	310	1820	1500×930×1370	660×660		
S11-M-800/10	0.98	7.50	1.0	360	2200	1600×1005×1430	660×660		
S11-M-1000/10	1.15	10.30	1.0	395	2475	1665×1080×1520	820×820		
S11-M-1250/10	1.36	12.00	0.9	470	2990	1745×1150×1625	820×820		
S11-M-1600/10	1.64	14.50	0.8	555	3375	1840×1230×1685	820×820		
S11-M-2000/10	2.15	18.90	0.5	715	4300	1925×1255×1885	820×820		
S11-M-2500/10	2.55	22.50	0.4	990	5370	2125×2370×2410	1070×1070		

型号 Model	空载损耗(kW) No load loss	负载损耗(kW) Load loss	空载电流(%) No load current	短路阻抗(%) Short-circuit impedance	重量(kg) Weight		外形尺寸(mm) Dimensions		
					油重 Oil weight	总重 Total weight	长 × 宽 × 高 L × W × H	轨距 Rail distance	
S14-M-50/10	0.10	0.74	0.30	4	60	445	850×530×955	400×400	
S14-M-80/10	0.13	1.06	0.25		90	550	960×610×990	400×400	
S14-M-100/10	0.15	1.27	0.25		100	660	1000×680×990	400×400	
S14-M-125/10	0.17	1.53	0.25		115	710	1050×730×1040	550×550	
S14-M-160/10	0.20	1.87	0.25		130	930	1085×780×1085	550×550	
S14-M-200/10	0.24	2.21	0.25		140	980	1105×780×1105	550×550	
S14-M-250/10	0.29	2.60	0.25		175	1160	1235×800×1150	550×550	
S14-M-315/10	0.34	3.10	0.25		200	1310	1280×825×1240	550×550	
S14-M-400/10	0.41	3.65	0.20		225	1510	1330×825×1245	550×550	
S14-M-500/10	0.48	4.37	0.20		250	1785	1365×850×1325	660×660	
S14-M-630/10	0.57	5.27	0.20		290	2050	1485×1050×1380	660×660	

三相有载调压配电变压器
Three-phase distribution transformer with OLTC

型号 Model	空载损耗(kW) No load loss	负载损耗(kW) Load loss	空载电流(%) No load current	短路阻抗(%) Short-circuit impedance	重量(kg) Weight		外形尺寸(mm) Dimensions		
					油重 Oil weight	总重 Total weight	长 × 宽 × 高 L × W × H	轨距 Rail distance	
SZ11-250/10	0.44	3.42	1.0	4	310	1370	1580×755×1400	550×550	
SZ11-315/10	0.53	4.10	1.0		335	1430	1570×800×1485	550×550	
SZ11-400/10	0.64	4.95	1.0		370	1680	1735×1020×1490	550×550	
SZ11-500/10	0.76	5.89	0.9		445	1920	1725×925×1610	660×660	
SZ11-630/10	0.96	7.26	0.9		520	2220	1850×1075×1640	660×660	
SZ11-800/10	1.12	8.89	0.8		560	2770	2295×1080×2250	660×660	
SZ11-1000/10	1.36	10.43	0.7	4.5	570	2930	2230×1140×2125	820×820	
SZ11-1250/10	1.56	12.40	0.7		795	3560	2515×1155×2150	820×820	
SZ11-1600/10	1.92	14.80	0.6		970	3940	2565×1225×2150	820×820	
SZ11-2000/10	2.15	18.90	0.6	5.5	1080	4950	2670×1255×2310	820×820	
SZ11-2500/10	2.70	23.60	0.5		1110	5610	2115×2380×2335	1070×1070	

型号说明 Model Coding

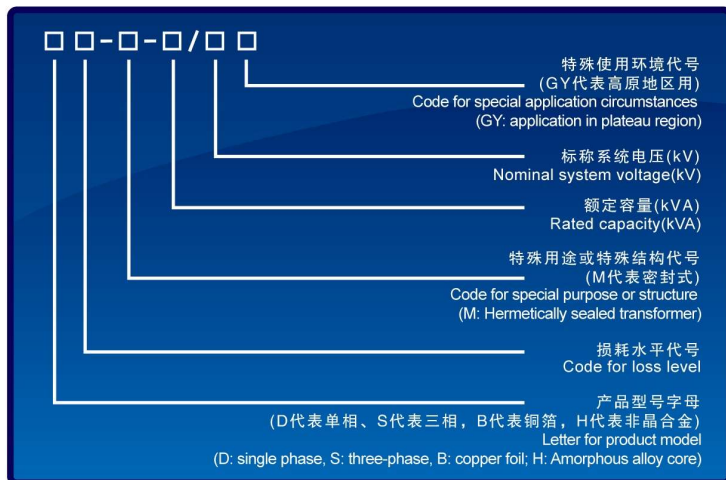

外形图 Structural Chart

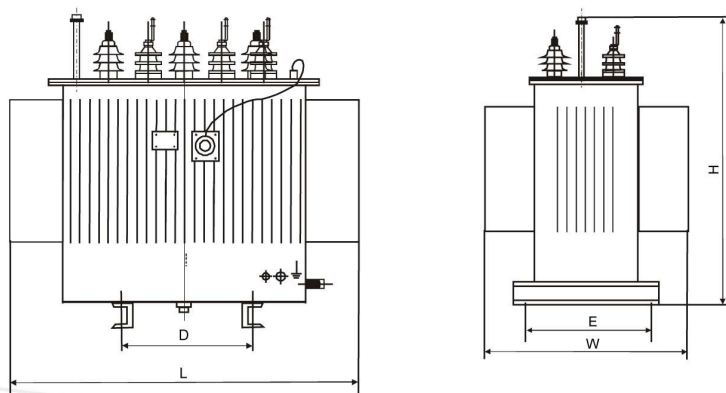

技术参数 Technical Parameters

以下数据仅供参考，公司保留数据变动的权利
Technical data are subjected to change without prior notice

型号 Model	容量 (kVA) Capacity	损耗(kW) Loss		空载电流(%) No load current	短路阻抗(%) Short-circuit impedance	重量(kg) Weight		外形尺寸(mm) Dimensions			
		空载 No load	负载 Load			油重 Oil weight	总重 Total weight	长 L	宽 W	高 H	轨距 Rail distance
S11-M-30/20	30	0.09	0.63	2.1	5.5	80	500	700	650	900	400x400
S11-M-50/20	50	0.12	0.91	2.0		100	600	730	690	950	400x400
S11-M-80/20	80	0.17	1.30	1.8		120	700	770	720	1000	400x550
S11-M-100/20	100	0.19	1.57	1.6		150	750	810	760	1050	400x550
S11-M-125/20	125	0.23	1.88	1.5		180	820	860	780	1100	550x550
S11-M-160/20	160	0.27	2.30	1.4		190	855	910	805	1145	550x550
S11-M-200/20	200	0.32	2.72	1.3		200	1050	950	830	1100	550x550
S11-M-250/20	250	0.38	3.18	1.2		225	1090	970	845	1090	550x550
S11-M-315/20	315	0.46	3.81	1.1		260	1280	1000	900	1250	550x550
S11-M-400/20	400	0.54	4.50	1.0		280	1455	1030	925	1395	550x550
S11-M-500/20	500	0.65	5.38	1.0	350	1850	1250	940	1550	660x660	
S11-M-630/20	630	0.77	6.48	1.0	6	405	2135	1415	880	1657	660x660
S11-M-800/20	800	0.93	7.84	0.8		450	2550	1600	1000	1700	820x820
S11-M-1000/20	1000	1.09	10.76	0.7		495	2700	1723	1133	1614	820x820
S11-M-1250/20	1250	1.29	12.54	0.7		560	3000	1800	1200	1700	820x820
S11-M-1600/20	1600	1.56	15.15	0.6		580	3400	1860	1290	1730	820x820
S11-M-2000/20	2000	1.85	18.18	0.6		750	4050	1950	1290	1900	820x820
S11-M-2500/20	2500	2.22	21.11	0.5		1100	5500	2190	2450	2500	1070x1070

产品应用领域

该产品具有功能齐全、安全性好、维护简单、占地面积小、成套性强、投资少、安装快捷、施工方便、造型美观等特点。广泛应用于建筑工地、车站、码头、矿山油田等企业事业单位及其它临时供电的场所。



Applications

This product has advantages of multi-function, reliable operation, easy for maintenance, highly integrated, fast installation, elegant features. It's very popular in construction site, stations, docks, mining & oil industries, and other sites requiring temporary power supply.



SZ11系列35kV有载调压电力变压器技术数据
35kV (SZ11 series) Power Transformer with OLTC

型号 Model	额定容量 (MVA) Rated capacity	额定电压 (kV) Rated voltage			联结组 标号 Vector group	空载损耗 (kW) No-load loss	负载损耗 (kW) Load loss	空载电流 (%) No-load current	阻抗电压 (%) Short-circuit impedance	重量(MT) Weight		外形尺寸(mm) Dimensions				
		高压 HV	高压分接范围 Tapping range of HV	低压 LV						油重 Oil weight	总重 Total weight	H	L	W	HL	T1×T2
SZ11-2000/35	2000	35		6.3 10.5	Yd11	2.25	17.7	0.7	6.5	1920	6770	2675	3030	1500	4500	1070 × 1070
SZ11-2500/35	2500					2.68	20.5	0.7		2150	8140	2710	3160	2000	4700	
SZ11-3150/35	3150					3.19	22.1	0.7		2445	9020	2770	3340	2760	4900	
SZ11-4000/35	4000					3.85	29.0	0.7	7.0	2560	10600	2850	3680	2900	5100	
SZ11-5000/35	5000					4.46	32.7	0.7	2980	12280	2900	3800	3200	5300		
SZ11-6300/35	6300					5.46	36.6	0.6	3670	13580	2970	3910	3400	5500		
SZ11-8000/35	8000					7.70	40.4	0.5	7.5	4250	17850	3120	4170	3250	5800	
SZ11-10000/35	10000					9.10	47.8	0.4	4860	20940	3250	4250	3460	6100		
SZ11-12500/35	12500					10.71	56.5	0.4	5020	22300	3400	4550	3690	6400		
SZ11-16000/35	16000					13.09	69.1	0.4	6310	27240	3640	4600	3890	6800		
SZ11-20000/35	20000	15.48	83.1	0.4	8.0	7070	32530	3770	4700	4090	7100					
SZ11-25000/35	25000	18.40	98.2	0.3	8270	39240	3930	5130	4200	7300						
SZ11-31500/35	31500	21.95	112.2	0.3	9500	43320	4210	5530	4450	7500						
SZ11-40000/35	40000	26	146	0.3	11600	51700	4520	5600	4670	8800						
SFZ11-54000/35	54000	32	180	0.3	10.5	14300	66000	4625	6065	5110	9500					

说明：钱江电气可为用户特殊设计技术参数不同于上表的产品。
Notes: Specification different from above listed product is available.

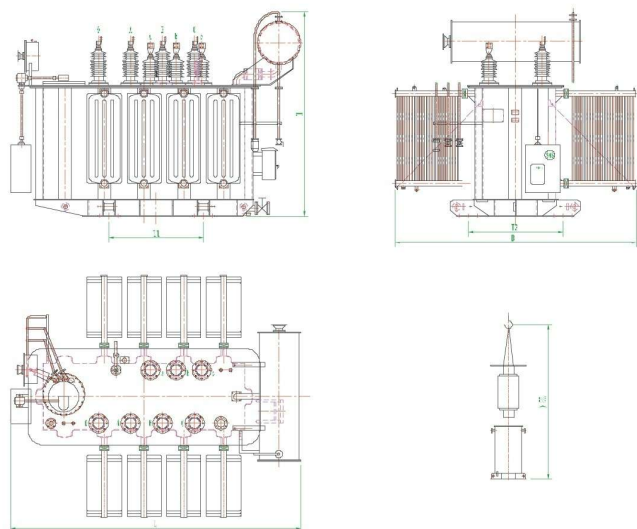

35kV系列三相双绕组变压器外形结构参考图
Outer Diagram of 35kV series 3-phase 2-winding Transformer

产品应用领域

该产品具有功能齐全、安全性好、维护简单、占地面积小、成套性强、投资少、安装快捷、施工方便、造型美观等特点。广泛地应用于建筑工地、车站、码头、矿山油田等企业事业单位及其它临时供电的场所。

Applications

This product has advantages of multi-function, reliable operation, easy for maintenance, highly integrated, fast installation, elegant features. It's very popular in construction site, stations, docks, mining & oil industries, and other sites requiring temporary power supply.

